

U3E/U5E/U6A Series Controller

instruction manual

Before using this controller, please read the instruction manual and fully understand its contents.

Please designate a custodian to keep it safely in a designated location so that it can be read at any time.

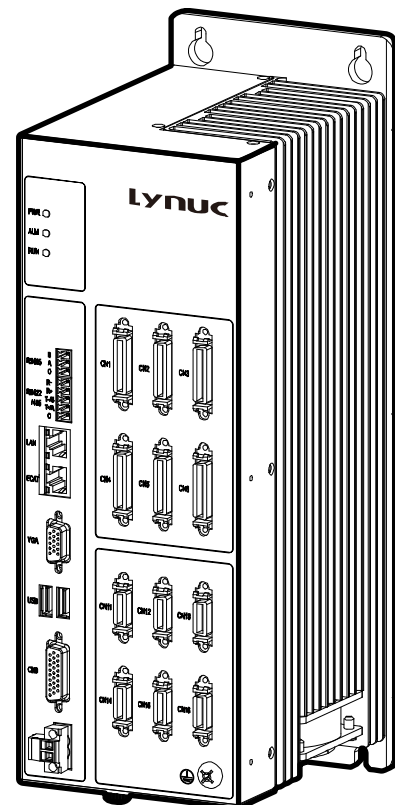
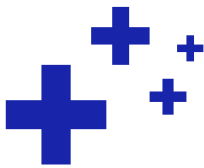

summarize

About this manual

- Name U3E/U5E/U6A Series Controller-Operating Instructions
- Type U3E/U5E/U6A Series Controller Electrical and Structural Characteristics and Installation Instructions
- Version V1.9

Instruction manual use

These instructions should be used during installation

This manual is intended to be read by

This instruction manual is oriented:

- Electrical Engineer
- Product technicians
- Technical service staff
- Product users

Operational prerequisites

Readers should:

- Familiarize yourself with the relevant concepts in the instruction manual
- Trained in the installation of U3E/U5E/U6A series controllers

Description of the revision

releases	Release Date	revised description
V1.9	2023-04-07	Table 3-9 Updated pin 13-20 description, updated control cable diagram for Appendix A.4 Feedback Terminal

☞ Reference documents (product specifications, operation manuals, technical data manuals)

CONTENTS

1. Safe use	1
1.1 Basic matters of safe operation	1
1.2 Safe work practices for installation	2
1.3 Personal injury prevention	3
1.4 Product Damage Prevention	4
2. Products	6
2.1 Product Overview	6
2.2 Product Features	7
2.3 Product Specifications	8
3. Hardware Interface and Installation Distribution	10
3.1 device connection	10
3.1.1 U3E Controller Connections	11
3.1.2 U5E Controller Connection	12
3.1.3 U6A Controller Connection	13
3.1.4 Selection List	14
3.2 hardware interface	18
3.2.1 CN1/2/3/4/5/6 Interface Description	20
3.2.2 CN11/12/13/14/15/16 interface description	23
3.2.3 CN9 Interface Description	25
3.2.4 VGA Interface Description	26
3.2.5 Power Input Connector	27
3.2.6 Serial Input Interface	28
3.2.7 Network Interface	29
3.3 Controller operation status indicator	29
3.3.1 Controller Status Indicator	29
3.3.2 Network Interface Indicator	30
4. Controller Installation Instructions	32
4.1 Pre-installation	32
4.1.1 Tools required for installation	32
4.1.2 External accessories required for installation	32

4.1.3 Cable Preparation and Fabrication	32
4.2 Fixed Installation	33
4.2.1 Controller appearance and mounting hole size	33
4.2.2 Controller Accessory Installation	35
4.3 Wiring Guide	35
4.4 Ground connection method	36
4.5 Pre-power-up test	36
4.5.1 Visual inspection of parts	37
4.5.2 Installation check	37
4.5.3 Connection check	38
4.5.4 Confirmation of power supply voltage	38
4.6 Installation Notes	38
5. Controller common faults and processing	39
5.1 Host Troubleshooting	39
5.2 Electrical Control System Malfunction	39
5.2.1 hardware failure	40
5.2.2 software failure	42
Appendix A - Cable Drawings	43
A.1 PWM Mode Connecting the control cable between the NC unit and the driver	43
A.2 PFM Mode Connecting the Control Cable of Yaskawa Drive	44
A.3 PFM Mode Connecting Control Cables for Panasonic Drives	45
A.4 Control cable for feedback terminal	46
A.5 CN9 Control Cable for Connecting Yaskawa Drive	47
A.6 CN9 Control cable for connecting Panasonic drives	48
A.7 CN9 Connecting Control Cables for Magmetric Drives	49

1. Safe use

summarize

U3E/U5E/U6A series controllers are precision electronic products, for the safety of the operator and machinery and equipment, please be sure to turn to professional electrical engineers to install, test and adjust the parameters of the product instruction manuals are labeled with "**Danger**", "**Warning**", "**Caution**" and other symbols of the instructions, please be sure to read carefully. The instruction manual of this product has the symbols of "Danger", "Warning", "**Attention**" and so on, please be sure to read it carefully. If there is any doubt, you can contact our branch offices around the world for consultation, or directly consult with the relevant known technical personnel of our company, and our professional staff will be happy to serve you.

1.1 Basic matters of safe operation

summarize

This manual includes safety-related precautions to ensure the safety of the installer and to prevent damage to the controller, and describes them in the body of the text as "**WARNING**" and "**CAUTION**" according to their level of importance in terms of safety, and the related supplemental descriptions are described as Additional instructions are described as "**Notes**".

These **DANGERS, WARNINGS, CAUTIONS** and **INSTRUCTIONS** must be read before use. **DANGER, WARNING, CAUTION, and INSTRUCTIONS** before use.

distress



Indicates that if this hazard cannot be avoided, the result is likely to be serious injury or death.

warnings



Indicates that there is a potential risk of serious injury or death if this hazard cannot be avoided.



take note of

Indicates that violating this precaution may damage the equipment or shorten its life.

clarification

Indicate additional instructions other than danger, warning and caution.

1.2 Safe work practices for installation

summarize

For safe use of this equipment, please read and be sure to observe the following safe work practices before installation.



warnings

1. Please read the instruction manual thoroughly and understand its contents.

The instruction manual describes how to operate the equipment for installation and commissioning. Before installing the equipment, be sure to read and fully understand the contents of the instruction manual. Do not operate the equipment using procedures or methods not described in the instruction manual.

2. Equipment operators must be appropriately qualified.

The equipment operator must have received the necessary training on the installation and commissioning of the equipment, have sufficient knowledge of safe operation, and be authorized by the person responsible for safety in the user enterprise. The enterprise management should carry out the safety and operation of the work of the guidance.

3. Please observe the safety precautions.

To operate this equipment safely, be sure to observe the safety precautions recorded in the instruction manual and the safety precautions recorded in the warning labels. Failure to observe the precautions may result in a major

personal accident.



take note of

- When connecting to external devices, use standard cables.
- If standard cables are not used, malfunctions may occur due to differences in specifications. For details, please contact our maintenance personnel.

1.3 Personal injury prevention

summarize

The following is a description of safe work practices in terms of personal safety precautions.

To protect the safety of the installer, please read carefully and be sure to observe the following.



warnings

1. Use the connection cable supplied with the unit.
 - For interconnection of modules, use the connection cable supplied with the unit.
 - When selecting the main grid AC power cable, use the connection cable supplied with the unit.
 - To avoid discharge and fire, do not exceed the voltage range outside the Lynuc limit.
2. Make sure all ground wires are properly connected.
 - To avoid leakage, connect all module grounds to the main ground. Make sure all ground connections are correct before connecting the unit's inputs and outputs.
 - Before adding power to the unit, make sure it is grounded. And to avoid leakage, make sure all ground connections are correct.

3. Ensure a safe working environment.
 - Do not work in a humid environment. To avoid electrical leakage, work in an environment where the relative humidity is less than 75% (no condensation) and the temperature is less than 58°C.
 - To avoid danger, do not work in explosive atmospheres.

1.4 Product Damage Prevention

summarize

The following describes safe work practices for preventing product damage.

To protect the integrity of the product in use, please read and be sure to observe the following.



warnings

1. Avoidance matters:
 - Keep the CNC unit as far away as possible from coolant, chemicals, impact objects, and other items that may cause damage to it.
 - Please try to stay away from sources of electromagnetic interference such as:
 - Large loads that share an AC power line with the unit.
 - Portable transmitters (cordless telephones, wireless transmitters).
 - Near the wireless/TC transmitter.
 - Arc welding machines.
 - High-voltage power lines.
 - Avoid interference from the machine tool. The machine must be uncoupled from all interference-generating factors (relay windings, current contactors, motors, etc.).
 - Please do not disassemble the controller by yourself, otherwise it will easily cause aging or damage to the connectors.
 - Please do not remove the batteries from the controller card, so as not to lose the information of the board and cause the controller not to work normally. When replacing the batteries, please ensure that it is

done within 2 hours.

2. About the power supply:

- Use an externally regulated 24V DC power supply for inputs and outputs.
- The zero voltage of the external power supply must be connected to the machine's mains grounding point.
- Analog inputs and outputs are recommended to be connected with shielded cables and their shields connected to the corresponding pins.

3. Relevant work environment:

- The operating environment must be between °C0 and °C58.
- Storage temperature must be between -10°C and 60°C.
- To ensure sufficient space between the center unit and the surrounding walls, refer to the installation instructions.
- Use in indoor settings.
- If it is used in a special environment that does not meet the above conditions, the user should propose it at the time of ordering to ensure that the product can work reliably.

2. Products

2.1 Product Overview

summarize

U3E/U5E/U6A series are developed by Shanghai Lynuc Technology Co., Ltd. to support multi-channel, high-performance, five-axis linkage controllers for medium and high-end machining equipment. Using EtherCAT bus to connect with other equipment, more stable and simple, transmission speed is greatly improved. Its body is small and exquisite, powerful, support PWM + way control, high current loop frequency, to ensure the servo response. Its structure is safe, stable and reliable, and its machine panel can be customized and optional touch screen.

- **U3E:** Elite: Economical and Practical Controller
- **U5E:** Signature Edition: Extended Controller
- **U6A:** Supreme Edition: High Performance Controller

Model Description

U 5E-01 B

① ② ③ ④

① U Series Controllers

② Controller version number.

3E: 3-Axis PWM Economy Controller

5E: 6-axis PWM + extended controller

6A: High-performance PWM+ controller supporting TMM-type servo drives

③ Motherboard and Structure Model

01: C-Series Motherboards; 31: K-Series Motherboards

- ④ hardware version

2.2 Product Features

Supports Linear Motors.

- Supports many types of linear motors
- High speed, high acceleration, high precision, high response

Supports multiple encoder feedbacks.

- Supports incremental 5V TTL feedback
- Support 1Vpp increment with AEIF
- Support for Heidenhain Endat 2.2 absolute scales
- Support for Fagor SAL/S2AL type absolute scales
- Support for Nikon absolute encoders
- Renishaw absolute encoders with BISS-C protocol support
- Support for Panasonic absolute encoders
- Support Tamagawa Encoders

High openness.

- Can be equipped with Lynuc RTCP 5-axis CNC system
- Can be equipped with different models of Lynuc panels
- Lynuc can be equipped with various functions of the CNC system.

Communication/networking capabilities.

- Supports high speed and high capacity USB interface devices
- High-speed Ethernet communication
- EtherCAT bus control
- Supports remote diagnostics, monitoring and commissioning
- Supports one RS485, one RS422/RS485 serial port

2.3 Product Specifications

Product specification parameters are shown in the table below:

◎	☆	×
standard equipment	optional	not have

Table 2- 1 Product Specifications

sports event		norm	U3E	U5E	U6A
control unit					
hosts	CPU board	CPU core count	2	2	2
	CF card	data disk	4G	4G	32G
	random access memory (RAM)	Bytes	2G	2G	4G
	network interface	100M EtherCat	1	1	1
		100M EtherNET	1	1	1
	Extended Serial Interface	RS485	1☆	1☆	1☆
		RS422/485	1☆	1☆	1☆
	USB interface	Mobile Memory Interface	2	2	2
	SRAM	32Mbit	1	1	1
OLED display	Display of controller operating status	1	1	1	
shaft card	PCIE Universal Servo Card	UML-PCIE	1	1	1
	High response PWM servo	Frequency/HZ	9K	16K	20K
	Total number of control axes	Servo axes, spindles, auxiliary axes	16	16	16
	Servo axis type	Number of TMM servo axes	0	1	6
		PWM/PWM+Control number of axes	3	6	6
		Number of pulse servo axes	8	8	8
		EtherCAT bus type	6	6	6
	IO interface	Number of connectable IoEs	2	2	2
SPD connector	Spindle interface (pulse, feedback, IO)	1	1	1	
principal axis (in	Local spindle	Pulse Output, Pulse Feedback, Pulse 4-point output, 6-point input	1	1	1
	IoE Spindle	Pulse Output, Pulse Feedback	1	1	1

mechanics, optics, botany etc)		4-point output, 8-point input Analog 2 outputs, 2 inputs			
handwheels	Panel Handwheel	5-axis selection, X1, X10, X100	1	1	1
	IoE Handwheel	5-axis selection, X1, X10, X100	1	1	1
IoE	Spindle Interface, IO Points	IoE: 24*2 inputs, 16*2 outputs	☆	☆	☆
		Expandable universal spindle interface	☆	☆	☆

other than					
Input Power	DC 24V	⊙	⊙	⊙	
output power	DC 5V overcurrent protection	⊙	⊙	⊙	
Battery Specifications	3.6V lithium battery	⊙	⊙	⊙	
maximum power	150W	⊙	⊙	⊙	
Temperature around the control unit	Operation: 0~58 degrees	⊙	⊙	⊙	
	Storage: -10~60 degrees	⊙	⊙	⊙	
Ambient relative humidity (no dew, no frost)	Normal: ≤75%RH	⊙	⊙	⊙	
	Short-term (within one month): ≤95%RH	⊙	⊙	⊙	
vibratory	Running time: ≤0.5G	⊙	⊙	⊙	
	When not running: ≤1G	⊙	⊙	⊙	
electromagnetic compatibility emission	Conforms to EN55022 (CISPR22) ClassB, EN61000-3-2,-3.	⊙	⊙	⊙	
electromagnetic compatibility immunity	Conforms to EN61000-4-2,3,4,5,6,8,11, FN55024, Class A light industry standard	⊙	⊙	⊙	
sizes	336*110*167.6mm	⊙	⊙	⊙	
net weight	4.2KG	⊙	⊙	⊙	

3. Hardware Interface and Installation Distribution

3.1 device connection

Device connection included:

- 3.1.1 U3E controller connection
- 3.1.2 U5E Controller Connection
- 3.1.3 U6 U6A Controller Connection

The material specifications and other information corresponding to the serial numbers in the equipment connection diagrams are shown in [3.1.4 Selection list] .



warnings

After installing and turning on the controller, rigorously hot-plug it, otherwise it may cause damage to the circuits and device hardware!



take note of

In order to avoid being affected by power interference during use, please add a magnetic ring at each power line inlet.

How to use: Wrap the power cord around and through the center of the magnetic ring three or more times, keeping the ring as close to the controller as possible when connecting.

3.1.1 U3E Controller Connections

The connection diagram is shown below, the material specification and other information corresponding to the serial number in the diagram is shown in [Table 3-31 Controller Selection List] .

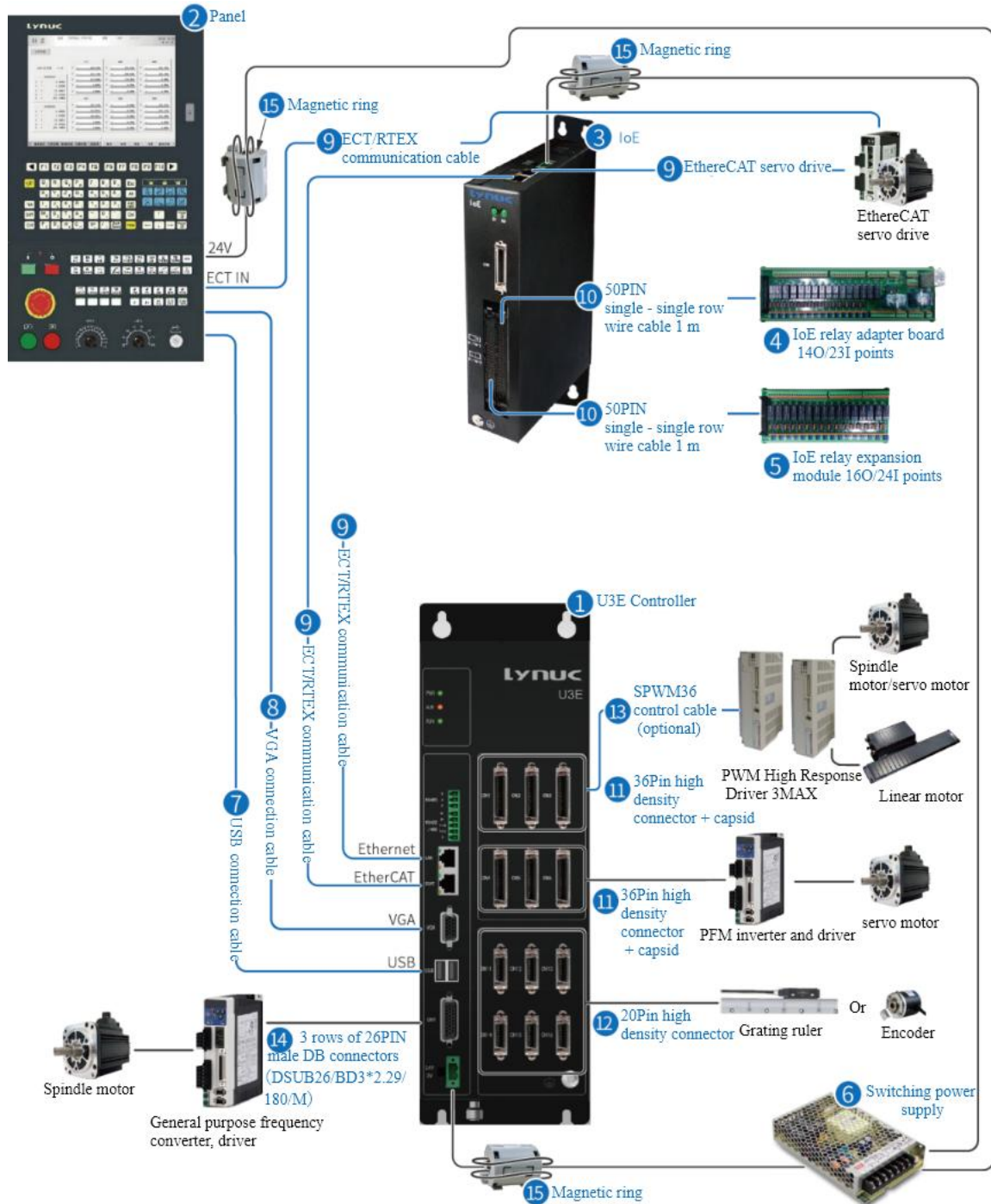

Figure 3- 1 U3E controller connection schematic

3.1.2 U5E Controller Connection

The connection diagram is shown in the figure, the material specification and other information corresponding to the serial number in the figure are shown in 【 Table 3-31 Controller Selection List 】 .

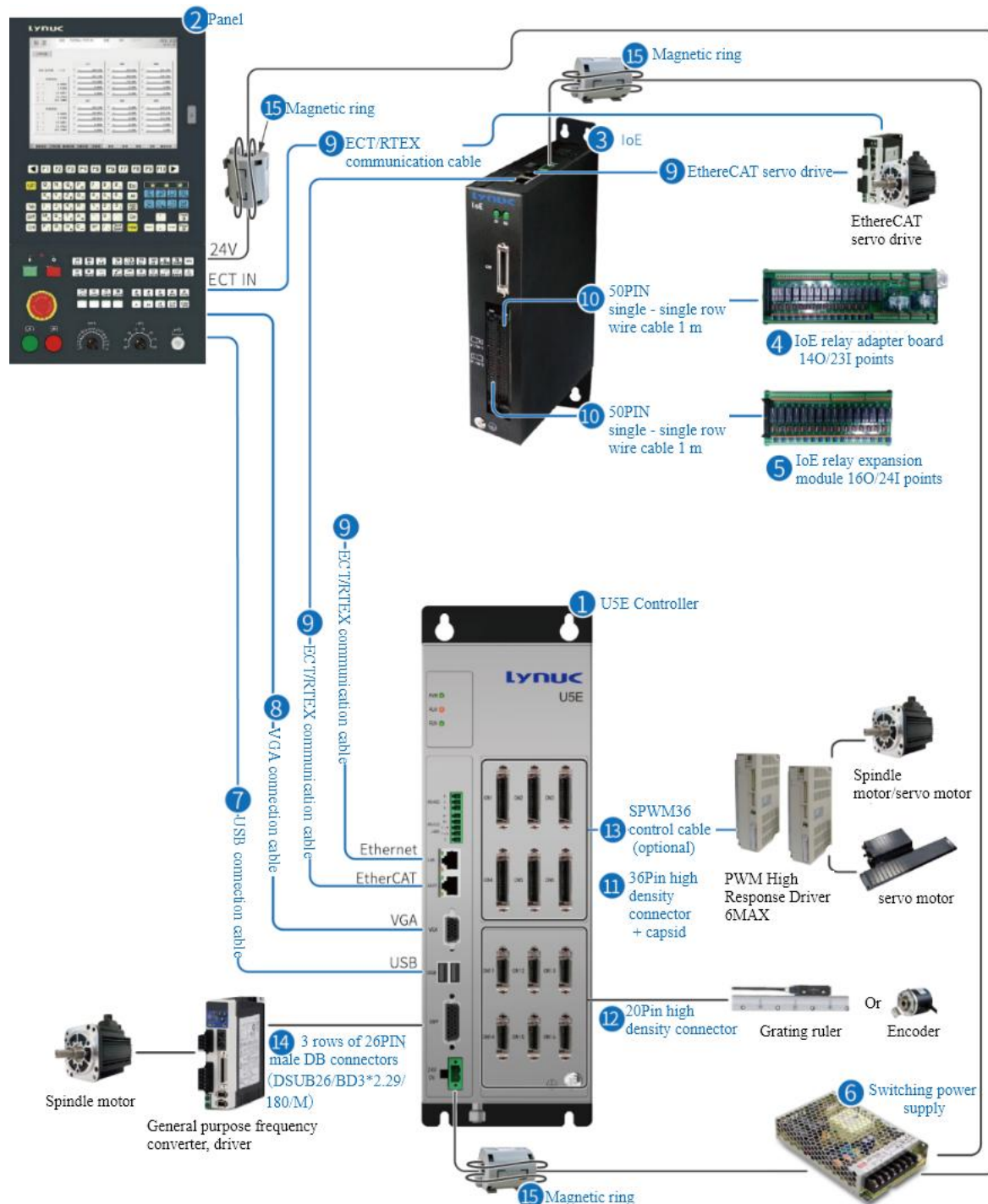

Figure 3- 2 U5E controller connection schematic

3.1.3 U6A Controller Connection

The connection diagram is shown below, the material specification and other information corresponding to the serial number in the diagram is shown in [Table 3-31 Controller Selection List] .

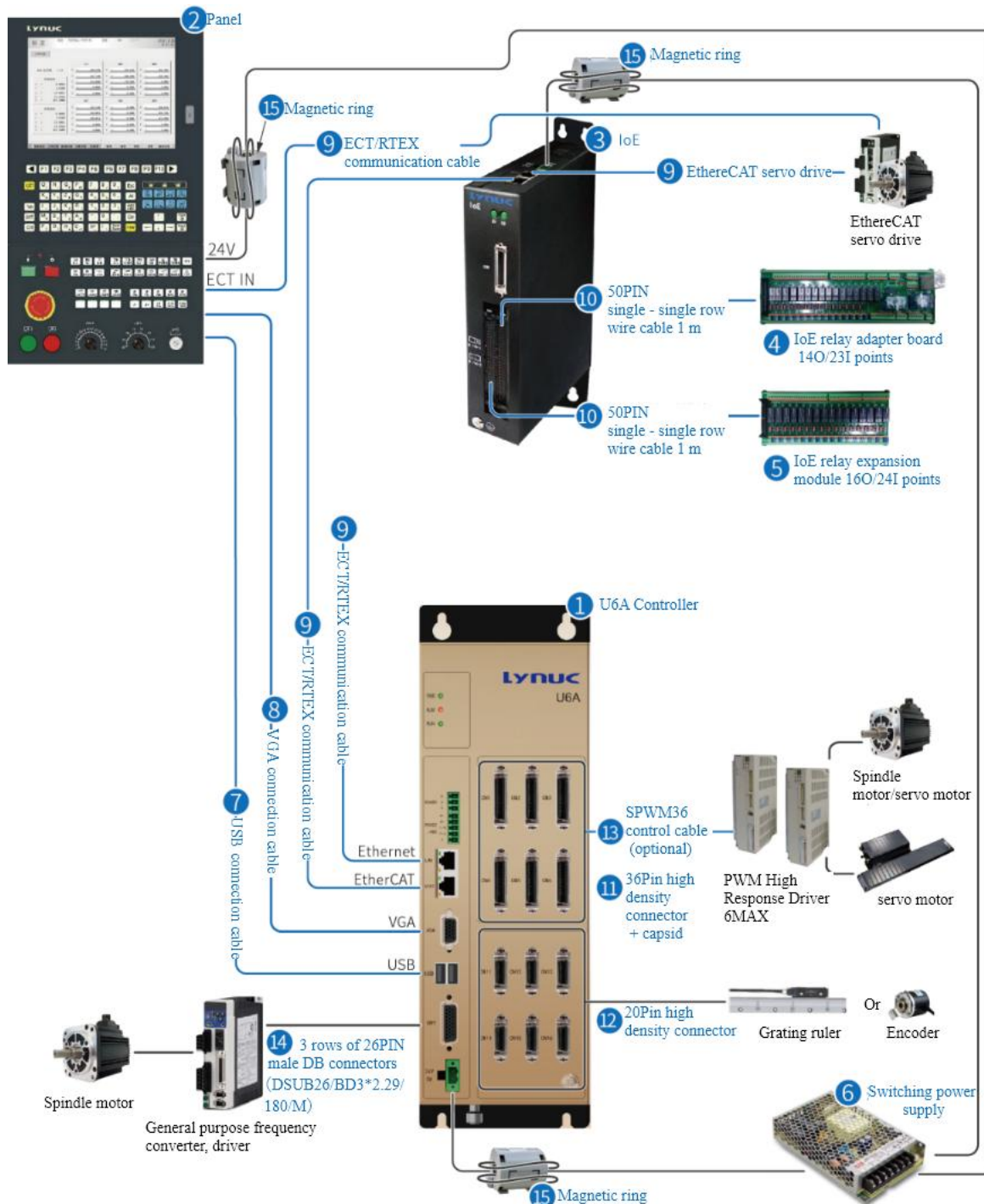

Figure 3- 3 Schematic diagram of U6A controller connection

3.1.4 Selection List

The following list of optional materials and specifications, you can choose the appropriate parts and accessories according to the actual use.

Figure 31 Fig. 3-31 Schematic diagram of U3E controller connection], [Fig. 3-32 U5E controller connection schematic diagram Figure 32 U5E Controller Connection Diagram], [Figure 3-33 U6A controller connection diagram The material specifications and material numbers corresponding to the serial numbers in the equipment connection diagrams are shown in the table below:

Table 3- 1 Controller Selection List

serial number	name (of a thing)	Specification	material number	note
1	U3E Controller	U3E-01B	NCU00027	
	U5E Controller	U5E-01B	NCU00026	
		U5E-31B	NCU00030	
	U6A Controller	U6A-31B	NCU00028	
2	15" Stainless Steel Panel on YCP06S (no logo)	LNK-PANEL15-01A-VGA	PCU00374	USB cable requires UM-USB2.0-A/F-5.0 (CA000176)
	15" Stainless Steel Panel on YCP06S (with logo)	LNK-PANEL15-01A-VGA	PCU00347	
	15" Stainless Steel Panel YCP06S Lower	lnk-panel15-01a-mcp	PCU00346	
	15" Aluminum Panel on YCP06S (with logo)	lnk-ss-panel15-ga-01a	PCU00387	
	15" Aluminum Panel YCP06S Down	lnk-ss-panel15-mcp-01a	PCU00388	
	10.4" One-piece Thin Film Printed Circuit Panel	PANEL10-RS-VGA	PCU00330	
	12" Panel - MDI-06S Upper - VGA	PANEL12-MDI-YCP06S-VGA	PCU00336	USB cable requires UM-USB2.0-A/A-5.0 (CA000423)
	12" Panel - Under 06S (with on-board handwheel round buttons)	PANEL12-06S-MCP-HV6	PCU00338	
	12" Panel - Under 06S (no on-board handwheel round buttons)	PANEL12-06S-MCP-V4	PCU00324	
	12" All-in-One Panel B (VGA) Kit 5m	PANEL12-03B-VGA-P50	01030001	
3	IoE finished product	IOE-01B	03020261	
4	IoE Relay Adapter Board 140/23I Points	IOE-RELAY-PW01	03020004	

5	IoE Relay Expansion Module 16O/24I Points	IOE-RELAY-EX 16	03020003	
6	Switching Power Supply 24V 150W	RS-150-24	E0000032	
7	USB Extension Cable A/F 5 meters	UM-USB2.0-A/F -5.0	CA000176	
	USB Connection Cable A/A - 5 meters	UM-USB2.0-A/A -5.0	CA000423	
8	VGA connection cable 1.8 meters	VGA-Q550-1.8	CA000154	
	VGA Connection Cable 5 meters	VGA-Q550-5.0	CA000156	
	VGA Connection Cable 10 meters	VGA-Q550-10.0	CA000174	
9	ECT/RTEX communication cable 0.5 m	LNK-RTEX/ECT -0.5	CA000162	
	ECT/RTEX communication cable 0.25 m	LNK-RTEX/ECT -0.25	CA000374	
	ECT/RTEX communication cable 2.0 m	LNK-RTEX/ECT -2.0	CA000190	
	ECT/RTEX communication cable 5.0 m	LNK-RTEX/ECT -5.0	CA000123	
10	50PIN Single - Single Row Wire Cable 1 meter	LNK-WHH50/1 M-FLEX	CA000433	
11	36Pin high density connector + housing	SM-36J	J0000412	
12	20Pin High Density Connector	SM-20J Suntone	J0000317	
13	SPWM36 control cable 2 meters	In-spwm36-50-2.0	CA000430	(Optional)
14	3 rows of 26PIN male DB connectors (DSUB26/BD3*2.29/180/M)	DBH26MAA	J0000046	
15	magnetic ring	TDK ZCAT3035-1330	E0000028	

Description:

The above table [Table 3-31 Controller Selection List The materials and specifications listed in [Table 31] are applicable to the three kinds of controllers U3E/U5E/U6A, and the corresponding parts and accessories can be selected according to the actual use.

[Example]

Using the U5E as an example, the specific selections and quantities for choosing to use IoE and 12" segmented panels (with half-load handwheels) are as follows:

Table 3- 2 U5E Selection List

Part classification	corresponding serial number	name (of a thing)	norm	material number	unit (of measure)	quantities
controllers	1	U5E Monoblock Controller	U5E-01A	NCU00026	classifier for individual things or people, general, catch-all classifier	1
	11	36Pin high density connector + housing	SM-36J	J0000412	classifier for individual things or people, general, catch-all classifier	6
	12	20Pin High Density Connector	SM-20J Suntone	J0000317	classifier for individual things or people, general, catch-all classifier	6
	14	3 rows of 26PIN male DB connectors (DSUB26/BD3 *2.29/180/M)	DBH26M AA	J0000046	classifier for individual things or people, general, catch-all classifier	1
	15	magnetic ring	TDK ZCAT303 5-1330	E0000028	classifier for individual things or people, general, catch-all classifier	1
IoE	3	IoE finished product	IOE-01B	03020261	classifier for individual things or people, general, catch-all classifier	1
	4	IoE Relay Adapter Board 14O/23I points	IOE-REL AY-PWO 1	03020004	radical (chemistry)	1
	5	IoE Relay Expansion Module 16O/24I Points	IOE-REL AY-EX16	03020003	radical (chemistry)	1
	9	ECT/RTEX communication cable 2.0 m	LNK-RT EX/ECT-2.0	CA000190	radical (chemistry)	1

	10	50PIN Single - Single Row Wire Cable 1 meter	LNK-WH H50/1M-FLEX	CA000433	radical (chemistry)	2
	11	36Pin high density connector + housing	SM-36J	J0000412	classifier for individual things or people, general, catch-all classifier	1
	14	magnetic ring	TDK ZCAT303 5-1330	E0000028	classifier for individual things or people, general, catch-all classifier	1
kneading board	2	12" Panel - MDI-06S Upper - VGA	PANEL1 2-MDI-Y CP06S-VGA	PCU00336	classifier for individual things or people, general, catch-all classifier	1
		12" Panel-06S (with onboard handwheel round button)	PANEL1 2-06S-M CP-HV6	PCU00338	classifier for individual things or people, general, catch-all classifier	1
	7	USB Extension Cable A/A 5 meters	UM-USB 2.0-A/A-5.0	CA000423	radical (chemistry)	1
	8	VGA Connection Cable 5 meters	VGA-Q5 50-5.0	CA000156	radical (chemistry)	1
	9	ECT/RTEX communication cable 5.0 m	LNK-RT EX/ECT-5.0	CA000123	radical (chemistry)	1
	14	magnetic ring	TDK ZCAT303 5-1330	E0000028	classifier for individual things or people, general, catch-all classifier	2
	switching mode power supply	6	Switching Power Supply 24V 150W	RS-150-24	E0000032	classifier for individual things or people, general, catch-all classifier
Control Cable	13	SPWM36 control cable 2 meters	In-spwm36-50-2.0	CA000430	radical (chemistry)	6 (Optional)

3.2 hardware interface

The U3E/U5E/U6A controller interfaces are shown below.

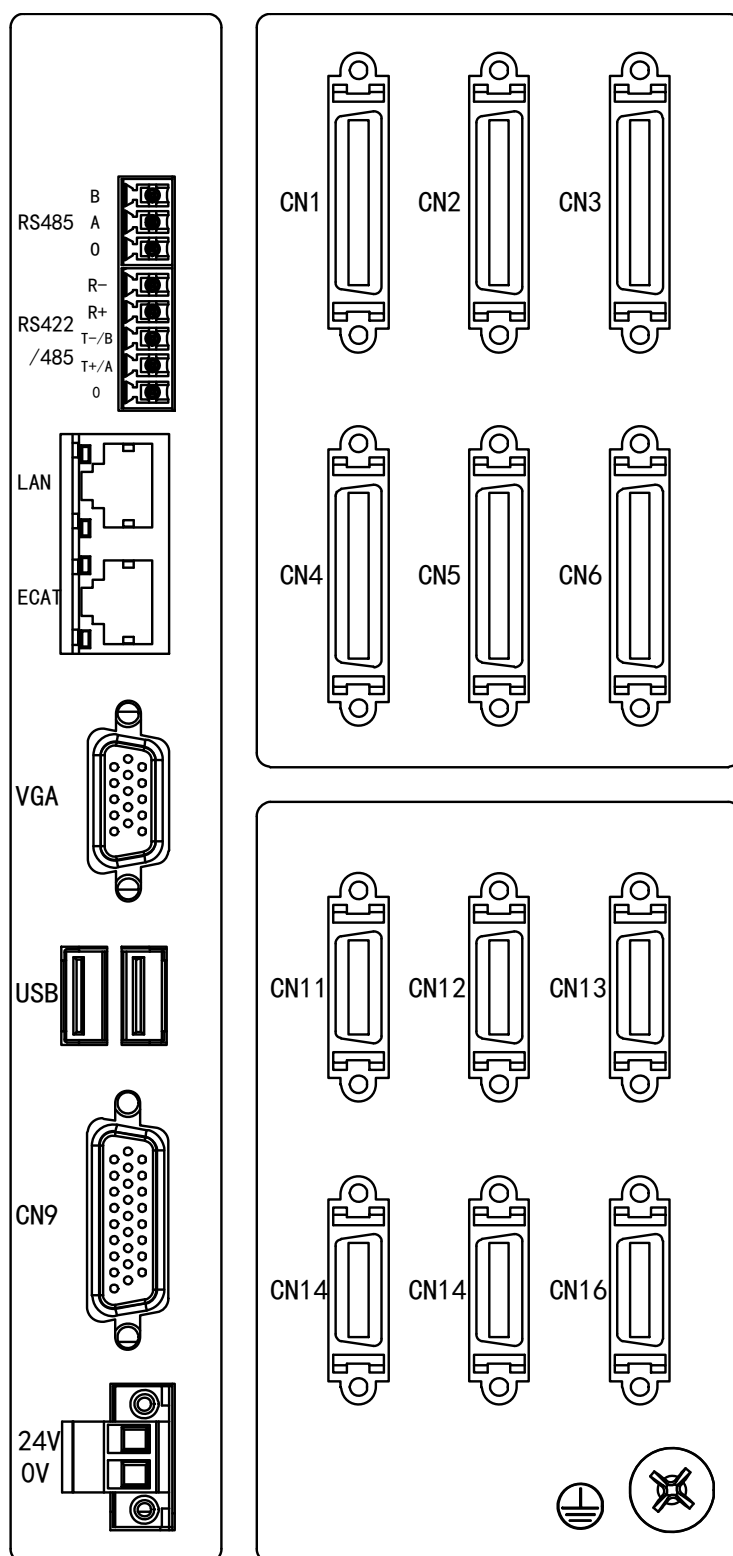

Figure 3- 4 U3E/U5E/U6A Controller Interface Diagram for Each Axis

Interface Description

⊙	×
standard equipment	not have

Table 3- 3 U3E/U5E/U6A Controller Hardware Interface Description

connector	functionality	U3E	U5E	U6A
CN1	PWM channel 1 for PWM control with main position feedback 1 1	⊙	⊙	⊙
	Auxiliary pulse control 1, which can be connected to the main position feedback 1 for double closed-loop control	⊙	⊙	⊙
CN2	PWM channel 2 for PWM control with main position feedback 2 2	⊙	⊙	⊙
	Auxiliary pulse control 2, which can be connected to the main position feedback 2 for double closed-loop control	⊙	⊙	⊙
CN3	PWM channel 3 for PWM control with main position feedback 3 3	⊙	⊙	⊙
	Auxiliary pulse control 3, which can be connected to the main position feedback 3 for double closed loop control	⊙	⊙	⊙
CN4	PWM channel 4 for PWM control with main position feedback 4 4	×	⊙	⊙
	Auxiliary pulse control 4, which can be connected to the main position feedback 4 for double closed loop control	⊙	⊙	⊙
CN5	PWM channel 5 for PWM control 5 with main position feedback 5	×	⊙	⊙
	Auxiliary pulse control 5, which can be connected to the main position feedback 5 to realize double closed loop control	⊙	⊙	⊙
CN6	PWM channel 6 for PWM control 6 with main position feedback 6	×	⊙	⊙
	Auxiliary pulse control 6, which can be connected to the main position feedback 6 for double closed loop control	⊙	⊙	⊙
CN11	Main position feedback 1	⊙	⊙	⊙
CN12	Main Position Feedback 2	⊙	⊙	⊙
CN13	Main Position Feedback 3	⊙	⊙	⊙
CN14	Main position feedback 4	⊙	⊙	⊙
CN15	Main Position Feedback 5	⊙	⊙	⊙
CN16	Main position feedback 6	⊙	⊙	⊙
RS485	RS485 serial port	⊙	⊙	⊙
RS422/485	RS422/485 serial port	⊙	⊙	⊙
LAN	Ethernet network interface for remote commissioning and viewing	⊙	⊙	⊙

ECAT	EtherCAT bus interface, expandable EtherCAT motor	⊙	⊙	⊙
CN9	SPD interface for spindle interface (supports pulse, feedback and IO)	⊙	⊙	⊙
VGA	VGA display connector for general connection to panel displays	⊙	⊙	⊙
0V	DC24V negative connector	⊙	⊙	⊙
24V	DC24V positive input	⊙	⊙	⊙
USB	USB device interface, keyboard interface	⊙	⊙	⊙

3.2.1 CN1/2/3/4/5/6 Interface Description

summarize

- CN1/2/3/4/5/6 can be used to control both PWM and PFM drives. The control wiring method is different for the two types of drivers;
- When CN1/2/3/4/5/6 are used for PWM control, the position feedback is connected to CN11/12/13/14/15/16, respectively;
- CN1/2/3/4/5/6 can be selected for PFM auxiliary pulse control, which uses the corresponding auxiliary pulse output (corresponding to pin PFM2) and auxiliary position feedback (ENC2), and can also be connected to the main position feedback from CN11/12/13/14/15/16, realizing the double closed-loop control.

3.2.1.1 CN1/2/3/4/5/6 Interface Pin Definitions

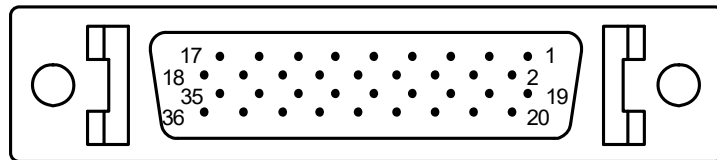

Figure 3- 5Schematic diagram of CN1/2/3/4/5/6 interfaces

CN1/2/3/4/5/6 PWM/PFM control mode interface pin definitions are shown in the table below:

Table 3- 4 CN1/2/3/4/5/6 Interface Pin Definitions

footno te	acronyms		footno te	acronyms	
	PWM	PFM		PWM	PFM
1	-	-	19	-	
2	-	-	20	-	
3	ADC_CLK+	-	21	ADC_CLK-	
4	ADC_STB+	-	22	ADC_STB-	
5	ADC_CUA+	ENC2_A+	23	ADC_CUA-	ENC2_A-

6	ADC CUB+	ENC2 B+	24	ADC CUB-	ENC2_B-
7	MT ENA+	-	25	MT ENA-	-
8	MT ALM+	ENC2 C+	26	MT ALM-	ENC2 C-
9	PWMATOP+		27	PWMATOP-	
10	PWMABOT+		28	PWMABOT-	
11	PWMBTOP+	PFM2 PULS+	29	PWMBTOP-	PFM2 PULS-
12	PWMBBOT+	PFM2 DIR+	30	PWMBBOT-	PFM2 DIR-
13	PWMCTOP+	-	31	PWMCTOP-	
14	PWMCBOT+	-	32	PWMCBOT-	
15	GND	GND	33	GND	GND
16	5V	5V	34	5V	5V
17		ENA	35	EGND	EGND
18		ALM	36	24V	24V

Description:

- PFM2 refers to auxiliary pulse output, and auxiliary position feedback interface ENC2 constitute auxiliary pulse control, this usage wiring is simple, convenient, more commonly used.
- The auxiliary pulse control corresponding to CN1~CN6 can be connected to the main position feedback at the same time to realize double closed-loop control.

3.2.1.2 CN1/2/3/4/5/6 PFM (Pulse) Interface Circuits**summarize**

- PFM Encoder Feedback Interface Circuit
- PFM command output
- PFM Driver Enable Interface Circuit
- PFM Drive Alarm Interface Circuit

Note: For pin numbers in the following interface descriptions, please refer to []. Figure 3-35

CN1/2/3/4CN1/2/3/4/5/6 Interface Diagrams]

1. PFM Encoder Feedback Interface Circuit

Table 3- 5 CN1/2/3 /4/5/6 PFM (Pulse) Encoder Feedback Circuits

footnote	acronyms	functionality	Circuit Principle
5	ENC_A+	TTL5VAB differential input	
23	ENC_A-		
6	ENC_B+		
24	ENC_B-	C-phase differential input	
8	ENC_C+		
26	ENC_C-		

Command output circuit



take note of

- The pulse control wiring diagram is shown in Appendix [A.2 PFM Mode Connecting Yaskawa Drive the Control Cable], [A.3 PFM mode connection to Panasonic driveControl cable for] ;

Table 3- 6 CN1/2/3/4/5/6 PFM (Pulse) Command Output Circuits

footnote	acronyms	functionality	Circuit Principle
11	PFM2 PULS+	Auxiliary pulse output	
29	PFM2 PULS-		
12	PFM2 DIR+		
30	PFM2 DIR-		

clarification

Lynuc Salk's full range of controllers support two types of pulse output:

- 1) Direction + Pulse Differential Outputs
- 2) AB phase 90 degree phase difference Differential outputs

PFM Driver Enable Interface Circuit

Table 3- 7 CN1/2/3/4/5/6 servo driver enable circuits

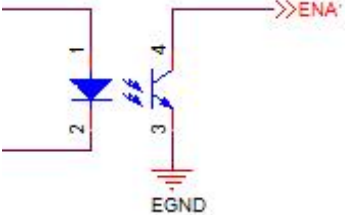
footnote	acronyms	functionality	Circuit Principle
17	ENA	Servo enable, output 0V* ① of DC24V when enabled.	 <p>Common 24V normally open contacts (0.2A)</p>

clarification

Lynuc controller in the enable, the output of 0V, normally open contacts, and the driver's DC24V is generally also through the Lynucsodium gram controller to obtain.

PFM Drive Alarm Interface Power Supply

Table 3- 8 Servo Drive Alarm Circuits

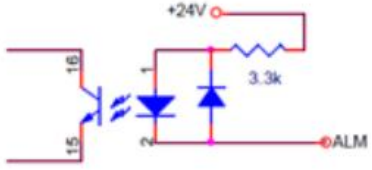
footnote	acronyms	functionality	Circuit Principle
18	ALM	Servo alarm ALARM signal input (input 0V active)	 <p>Maximum rate supports 10KHZ</p>

3.2.2 CN11/12/13/14/15/16 interface description

summarize

- CN11/12/13/14/15/16 are used in conjunction with CN1/2/3/4/5/6.
- When CN1/2/3/4/5/6 control the PWM driver, they correspond to the main position feedback of CN11/12/13/14/15/16, respectively.
- CN1/2/3/4/5/6 For PFM auxiliary pulse control, CN11/12/13/14/15/16 can be connected to the main feedback, thus constituting a double feedback and realizing full closed-loop control of the screw.

- CN11/12/13/14/15/16 can be connected to TTL 5V differential signals as well as absolute scale position feedback. The wiring methods and pin definitions for incremental differential feedback and absolute position feedback are different, so special attention should be paid when wiring.
- CN11/12/13/14/15/16 supports the broken wire detection function, and the first feedback (scale feedback) of the motor that corresponds to CN1/2/3/4/5/6 accessed under control supports broken wire detection.

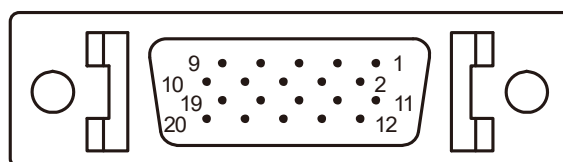

Figure 3- 6 CN11/12/13/14/15/16 Schematic diagram of the interface

Interface Pin Definitions

Table 3- 9 CN11/12/13/14/15/16 Interface Pins

footnote	use							clarification
	incremental send back inform	Absolute feedback						
		SAL ^①	End at 2.2 ^②	BISS-C [®]	NIKO N [®]	PANASON IC [®]	TAMAGA WA [®]	
1	0V	0V						
2	0V	0V						
3	5V	5V						
4	5V	5V						
5								
6								
7	A+	DAT	DAT	MA+(CL	SD+	PS+	DAT+	Absolute and relative common* encoders
8	A-	DAT	DAT	MA-(CLK	SD-	PS-	DAT-	
9	B+		CLK	SLO+(DA				
10	B-		CLK -	SLO-(DA T-)				
11	C+							
12	C-							
13-20								leave blank
housings	cable shield							

clarification

CN11/12/13/14/15/16 supports the following location feedback protocols:

- ① Hairy SAL serial protocol.
- ② Heidenhain Endat 2.0 serial protocol.
- ③ Renishaw BISS-C serial protocol.
- ④ Nikon absolute encoder.
- ⑤ Panasonic Absolute Encoder
- ⑥ Tamagawa Encoders

3.2.3 CN9 Interface Description

summarize

- CN9 is the spindle interface
- Support 1 channel PFM output
- Supports 1-channel encoder incremental feedback
- Supports 6 high-speed input ports.
- Supports 4 high-speed output ports.

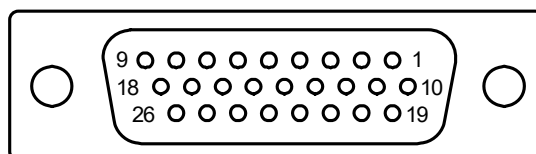

Figure 3- 7 Schematic diagram of the CN9 interface

Interface Pin Definitions

Table 3- 10 CN9 Pin Definitions and Circuitry

footnote	acronyms	functionality	Circuit Principle
1	ENC_AP	One way incremental encoder feedback	<p>The circuit diagram shows a vertical hatched bar representing the encoder. Two lines, labeled 'A+/B+/C+' and 'A-/B-/C-', enter from the left. The 'A+/B+/C+' line passes through a 200ohm resistor to pin 1. The 'A-/B-/C-' line goes to pin 3. A diode is connected between pins 1 and 3, with its cathode at pin 1. Pin 5 is connected to the other side of the diode.</p>
10	ENC_AN		
2	ENC_BP		
11	ENC_BN		
3	ENC_CP		
12	ENC_CN		

5	PLUSE_AP	One PFM output	
14	PLUSE_AN		
6	PLUSE_BP		
15	PLUSE_BN		
4	CH5V	CH5V	
13	CHGND	CHGND	
19	OUT1	4 output points	
20	OUT2		
21	OUT3		
16	OUT4		
25	OCOM		

22	IN1	6 input points	
23	IN2		
24	IN3		
7	IN4		
17	IN5		
8	IN6		
18	INCOM		
9	FGND	FGND	
26	F24V	F24V	

3.2.4 VGA Interface Description

summarize

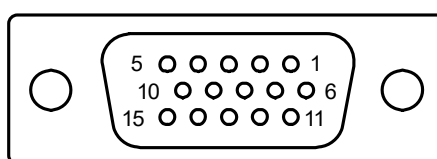

Figure 3- 8 Schematic diagram of VGA interface

Table 3- 11 VGA Interface Details

pinout	acronyms	Functional Description
1	RED	red fundamental color signal
2	GREEN	green signal
3	BLUE	blue fundamental color signal
5	GND	earth signal
6		

7		
8		
9	KEY	Empty, No Pin
12	ID1	Display identification bit 1, address code, I2C interface, interface used by the host to view information such as the display ID and model number
13	HSYNC	line synchronization
14	VSYNC	field synchronization
15	ID3	Display identification bit 3, address code, I2C interface, interface used by host computer to view information such as display ID and model number

3.2.5 Power Input Connector

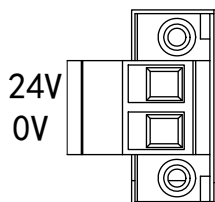

Figure 3- 9 Schematic diagram of the power input connector

The individual pins are defined below:

Table 3- 12 Power Input Connector Description

functionality	pin	Functional Description	interface description
Power Input	+	DC24V positive input	24V±10%/2A(DC) Power input
	-	DC24V negative input	



take note of

In order to prevent and reduce the interference of the peripheral grid on the power supply of the controller, the 24V power supply of the controller needs to be equipped with a separate switching power supply, the recommended model is: Meanwell RS-150-24. The power supply requires a voltage of 24V, an output current of not less than 6A, and the positive and negative polarities should not be reversed, as reversing the polarity may lead to the controller not being able to work, or be permanently damaged.

3.2.6 Serial Input Interface

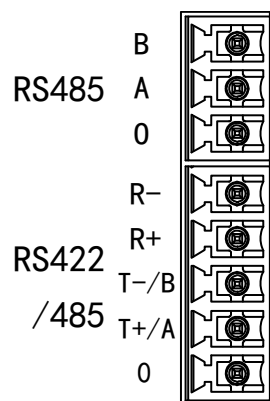

Figure 3- 10 Serial Input Interface

Table 3- 13 Serial Input Interface Description

connector	pin	Functional Description		interface description
RS485	B	485 Signal Negative		RS485 is an isolated interface with isolation voltage of 1000V, "0" is the reference level, which can be used according to the needs of the site.
	A	485 Signal Positive		
	0	485 Reference Level		
RS422/485	 	RS485	RS422	When 485 interface, only the three signals 0,A,B can be connected, when 422 interface, connect according to the definition of 0,T+,T-,R+,R-.
	R-	 	422 Receive Negative	
	R+	 	422 receiving positive	
	T-B	485 Signal Negative	422 Send Negative	
	T+/A	485 Signal Positive	422 sends positive	
	0	485 Reference Level	422 Reference Level	

3.2.7 Network Interface

The network interfaces consist of two, the EtherNET and EtherCAT interfaces, denoted by LAN and ECAT:

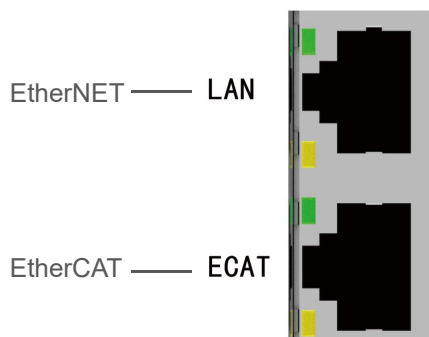

Figure 3- 11 EtherCAT and EtherNET network interface

Table 3- 14 Network Interface Descriptions

connector	Functional Description		interface description
LAN bus interface	Standard interface	Ethernet	EtherNet network interface, standard Ethernet interface.
ECAT bus interface	Standard interface	Ethernet	EtherCAT master interface to standard EtherCAT slave devices, including EtherCAT drives, I/O cards, and pulse converter card units for which Lynuc has confirmed support.

3.3 Controller operation status indicator

3.3.1 Controller Status Indicator

summarize

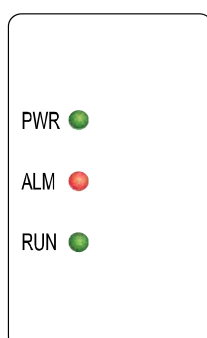

Figure 3- 12 Operation status indicator

Table 3- 15 Operational status indicators

connector	lantern	state of affairs	clarification
PWR	green light	go out (of a fire etc)	Power not connected
		vague (of speech)	Low supply voltage
		Ever Bright	Power on, power voltage normal
ALM	red light	go out (of a fire etc)	The system is functioning normally
		Ever Bright	PWM synchronization error, watchdog reporting error
RUN	green light	go out (of a fire etc)	power-on startup
		vague (of speech)	system startup
		Ever Bright	driver enable

Description:

"PWM synchronization error" means that the controller can set different PWM carrier frequencies for different channels, for example, channel 1~4 can be set to 10kHz, channel 5~6 can be set to 20kHz, but the carrier frequency of each channel must obey the multiplier relationship, otherwise, it will cause unsynchronization of PWM waveforms in each channel. Otherwise, it will cause the waveforms of PWM waveforms of each channel not synchronized.

3.3.2 Network Interface Indicator

summarize

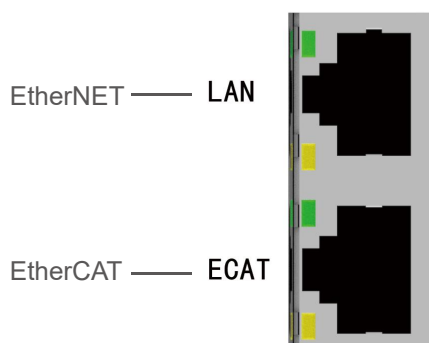

Figure 3- 13 Operation status indicator

Table 3- 16 EtherNet and EtherCAT Interface Indicator Definitions

connector	lantern	state of affairs	clarification
EtherNet LAN	green light	go out (of a fire etc)	Network not connected
		Ever Bright	Network is connected but no data transfer
		vague (of speech)	The network is connected and there is data transfer
	yellow light	go out (of a fire etc)	unplugged state
		Ever Bright	insertion state
EtherCAT ECAT	green light	go out (of a fire etc)	Network not connected
		Ever Bright	Network is connected but no data transfer
		vague (of speech)	The network is connected and there is data transfer
	yellow light	go out (of a fire etc)	unplugged
		Ever Bright	insertion state

4. Controller Installation Instructions

4.1 Pre-installation

4.1.1 Tools required for installation

Before installing the unit, prepare the following items:

- One screwdriver (M2)
- Phillips screwdriver (M5)
- Allen key
- socket wrench
- Multimeter, etc.

4.1.2 External accessories required for installation

- DC 24V power supply
- IOE Board
- relay board



take note of

In order to prevent and reduce the interference of the peripheral grid on the power supply of the controller, the 24V power supply of the U3E/U5E/U6A controller needs to be equipped with a separate switching power supply, and the recommended model is: Meanwell RS-150-24. The power supply requires a voltage of 24V, an output current of not less than 6A, and the positive and negative polarities should not be reversed, as reversing the polarity may lead to the controller not being able to work, or being permanently damaged.

4.1.3 Cable Preparation and Fabrication

If optional cables are not purchased, refer to Appendix A - Cable Drawings.

4.2 Fixed Installation

4.2.1 Controller appearance and mounting hole size

U3E/U5E/U6A products have the same external dimensions as shown below:

Unit: millimeters (mm)

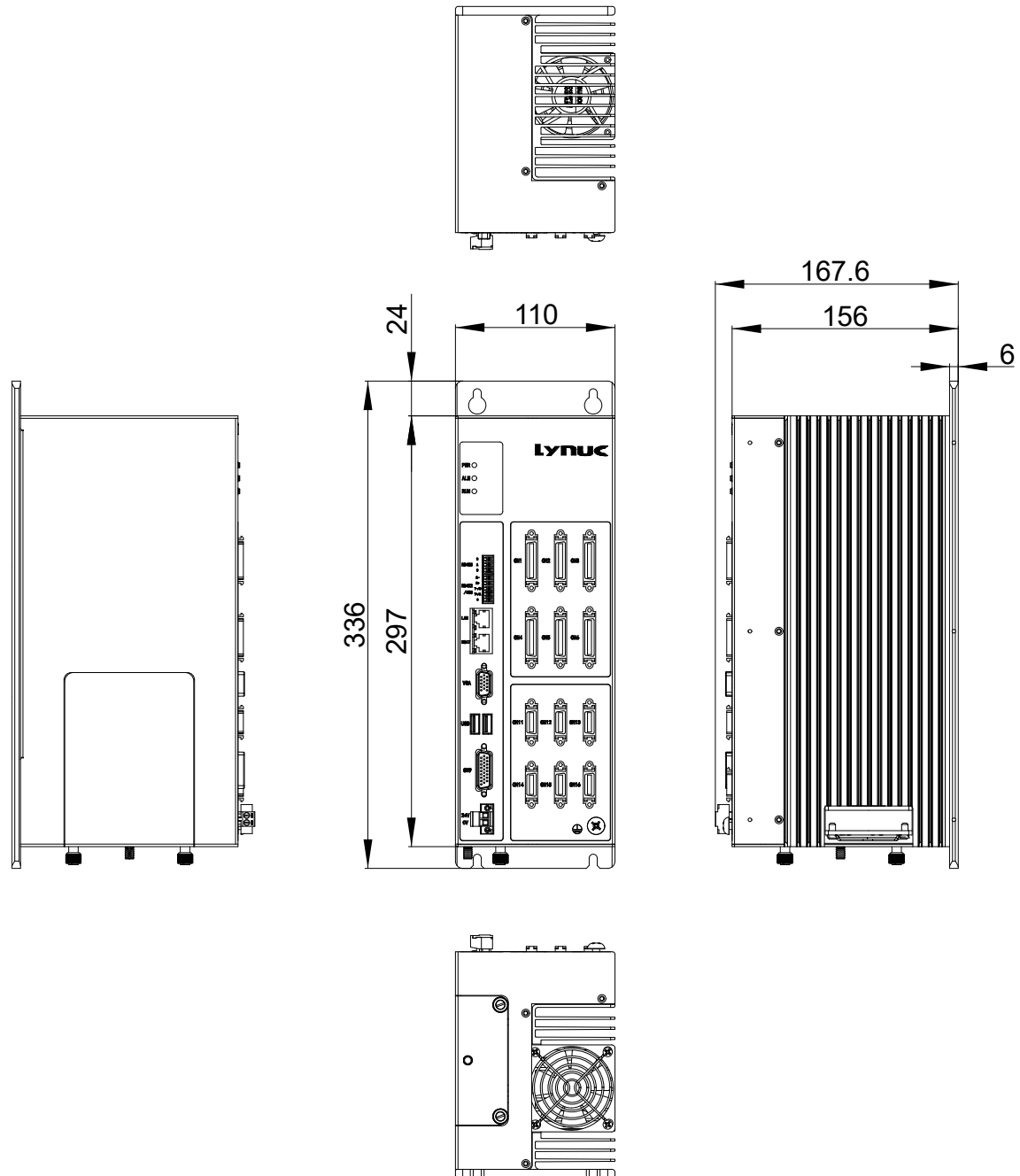

Figure 4- 1 Outer dimensions of the product

Installation, according to the product hanging hole position using 4 M5 screws locked in the hanging hole, after installation, lock the screws, the back of the mounting hole position and size as shown in the figure below:

Unit: millimeter (mm)

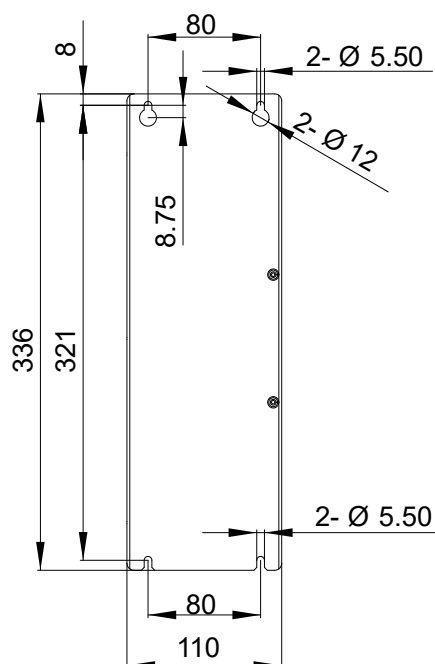

Figure 4- 2 Mounting Dimension Drawing-1

When installing, the front of the controller and the upper, lower, left and right, should ensure that there is enough distance, the specific dimensions are shown in the figure below, unit: millimeter (mm)

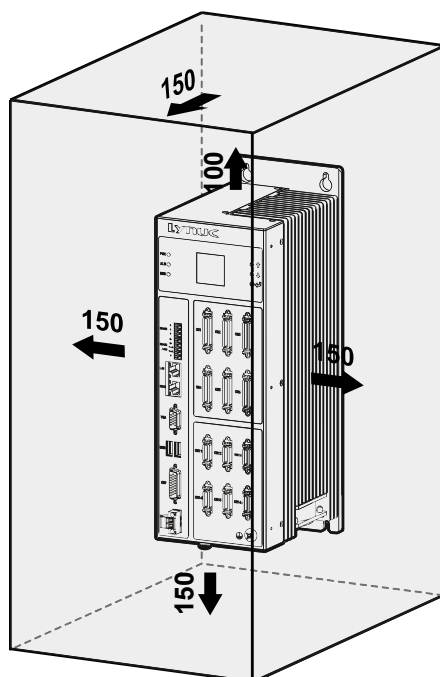

Figure 4- 3 Mounting Dimensions Diagram-2

**Attention:**

- Please leave enough space on the right side and lower end of the controller for wiring; try to keep the controller away from servo amplifiers, inverters and other high-power or heat-generating electrical units.
- To improve the heat dissipation performance of the controller, make sure that the air on both sides is unobstructed; and that the heat dissipation airflow reaches the exhaust fan quickly.
- Because of the large size and heavy weight of the controller, side mounting is generally not recommended. If side mounting must be done, a mounting bracket needs to be added, and the controller is fixed to the mounting bracket by means of flush mounting, and then the mounting bracket is mounted sideways.

4.2.2 Controller Accessory Installation

Please refer to the relevant manual for details.

Table 4- 1 Accessory Installation References

Installation Projects	bibliography
Panel Mounting	☞ Instruction Manual for Panels
IoE Installation	☞ IoE Input/Output Module - Instruction Manual

4.3 Wiring Guide

For cables arranged horizontally:

1. Arrange the individual cables horizontally and horizontally;
2. Overlap cables at the same level back and forth and tie them off with cable ties.



Figure 4- 4 Wiring Guide

4.4 Ground connection method

summarize

After each module is secured, lock the grounding cable to the grounding nut on the controller to lead to ground.

Cable Requirements

Generally, multi-stranded yellow and green flexible cables should be used with cold-pressed connectors at both ends. The length of the cable is based on the actual installation, just enough, not too long or curled. The wire diameter area is not less than $2(\text{mm}^2)$ or AWG14, and must be larger than the wire diameter of the equipment power supply.

4.5 Pre-power-up test

In the maintenance of CNC machine tools, in order to ensure the safe and reliable operation of the machine tool, regardless of whether the failure is related to the

following checks, usually should be the first to do the routine inspection and testing of the CNC system.

Testing Program:

- Component Appearance Inspection
- Installation check
- Connecting the power supply
- Confirmation of power supply voltage

4.5.1 Visual inspection of parts

A visual inspection of the CNC and servo drive should include the following.

- Check the appearance of the components of the MDI/CRT unit, machine operation panel, and other units for damage.
- Check that the control unit, servo driver, power supply unit, I/O and other units are firmly mounted and that the modules are not loose or detached;
- Check each connecting cable for breakage, insulation damage, or poor plugging.

4.5.2 Installation check

Check items:

- Check that the control unit, servo driver, power supply unit, I/O unit, and other units are securely mounted, and that the modules are not loose or detached.
- Check that the operating components on the panel and on the machine are securely mounted.
- Check that the connecting cable wires are arranged and fixed as required and that the cable plugs have been reliably stabilized.
- Check the wiring of each I/O connection terminal for looseness, firm installation, etc.

4.5.3 Connection check

Check items:

- Check that the power connections to the system and drive are correct.
- Check that the grounding wires of the CNC, Servo Driver, and I/O Unit are connected correctly, that the wire diameter is large enough, that the connection location is reasonable, and that the protective earth is a single point ground.
- Check that signals and cables have been reliably

- Make sure that the cable wiring from the controller to the YCP panel and the cable wiring from the YCP panel to the PRIO board is correct.
- Make sure the controller to drive wiring is correct.
- Make sure that the servo motor is properly wired to the servo motor driver.
- Make sure that all IOs are wired correctly and that the polarity of the IO levels is correct!
- Make sure all grounded signal wires are properly and adequately grounded.

4.5.4 Confirmation of power supply voltage

Check items:

- Please measure the resistance of the 24V input to confirm that there is no short circuit.
- Please make sure that there is DC24V power supply input normally.

4.6 Installation Notes

summarize

- 1) Control board card power supply power cord: 24V must be twisted.
- 2) All differential form signal cables must be twisted pair per group and the cables must be reliably shielded.
- 3) Strong machine power line to try to avoid the signal line and weak power line, prohibit signal line, weak power and strong power line in close proximity to the line.

5. Controller common faults and processing

5.1 Host Troubleshooting

summarize

The host of the CNC machine tool usually refers to the mechanical, lubrication, cooling, chip removal, hydraulic, pneumatic and protection parts of the composition of the CNC machine tool, the host of common failures are mainly:

- ① Mechanical transmission failures caused by improper installation, commissioning, operation and use of mechanical parts.
- ② Failure caused by interference of moving parts such as guideway spindle, excessive friction, etc.
- ③ Malfunctions caused by damage to mechanical parts, poor connections, etc., etc.

The main manifestation of the fault:

Transmission noise, poor machining accuracy, high operating resistance, non-operation of mechanical parts movements, damage to mechanical parts, etc.

Common causes of malfunctions:

Poor lubrication, clogged management of hydraulic and pneumatic systems and poor sealing are common causes of mainframe failures.

Mainframe Troubleshooting:

Regular maintenance of CNC machine tools, maintenance, control and eradication of "three leaks" phenomenon is to reduce the host part of the failure of important measures.

5.2 Electrical Control System Malfunction

summarize

Electrical control system failures are usually categorized into two main groups in terms of the type of components used and according to common usage.

- "Weak power" failure
- "Power" failure

clarification

- ① The "weak electric" part refers to the control part of the control system which is mainly composed of electronic components and integrated circuits. The weak electric part of the CNC machine tool includes CNC, PLC, MDI/CRT and servo drive unit, output unit and so on. "Weak electricity" failure and hardware failure and software failure;
- ② "Strong" part of the control system refers to the main circuit or high-pressure, high-power circuit of relays, contactors, switches, fuses, power transformers, motors, solenoids, travel switches and other electrical components and their control circuits. Although this part of the fault maintenance, diagnosis is more convenient, but because it is in high pressure, high current working condition, the chance of failure is higher than the "weak power" part. Must cause maintenance personnel enough attention.

5.2.1 hardware failure

summarize

Hardware failures are failures of integrated circuit chips, discrete electronic components, connectors, and external connection components of the above components (CNC, PLC, MDI/CRT, servo drive units, and input/output units).

Table 5- 1 Common Hardware Failures and Handling

fault diagnosis	Fault classification/cause	troubleshooting
Black screen display, unable to start	a) Only the display is black, the controller works normally.	The power supply to the monitor is not supplied, or the power supply terminals are disconnected.
		VGA cable not connected or not locked resulting in looseness
		The monitor has been artificially turned off, double-check the LED light on the back of the monitor, red means off; green means on; if it shows red, press the switch next to it to turn on the monitor
	b) The controller is not activated and there is no VGA output.	The 24V power supply to the controller may not be supplied, and the voltage may be low or reversed.
Power supply power is low, not using the recommended type of switching power supply, please ensure that the power of 150W		
Automatic restart during work		24V switching power supply power is not enough, may use the power, model is not correct
		The same switching power supply that powers devices other than the controller causes unstable power supply.
		Terminals are not locked, wires or terminals have poor contact, or even fall off

Table 5- 2 Common Hardware Failures and Handling

fault diagnosis	Fault classification/cause	troubleshooting
USB not recognized, unable to copy files	USB cable length is too long, or using a poor quality cable	Please use a standard USB cable, usually no longer than 5 meters
	USB cable is loose and not plugged in tightly	USB cables can be tightened by bundling them to prevent them from coming loose.
Incorrect display	black screen	Check whether the monitor's power is supplied; whether the switch is turned on; whether the VGA cable is plugged tightly
	Display color is not correct	Check whether the VGA cable is plugged in tightly; whether there are skewed or even broken pins
	The display area is not correct	Do the operation at the switch on the back of the monitor to make automatic adjustments

5.2.2 software failure

summarize

Software failure refers to the hardware under normal circumstances of action errors, data loss and other faults, common processing program errors, system programs and parameters of the change or loss, computer arithmetic errors and so on.

Table 5- 3 Common Software Faults and Handling

fault diagnosis	Fault classification/cause	troubleshooting
Startup failed during startup	a) GACC startup failure	The PCIe slot may be faulty, please make sure the center red LED on the controller is blinking; if it is blinking, it needs to be returned to service
	b) UI startup failure	
Network inaccessible, FTP inaccessible	a) Problems with network cables	Check if the network cable is plugged in tightly
	b) The network IP is not set, or the network segment and mask do not meet the requirements of the network.	Check the controller's configuration-network screen, set the IP address, set the correct netmask, etc.
	c) The corresponding port on the FTP server is not open and cannot be accessed	Check the network service settings of the FTP server and open the port required for FTP service: 21
	d) Incorrect FTP server configuration, or wrong password	Please enter the FTP configuration first to perform a diagnostic test

Appendix A - Cable Drawings

The following cable drawings are for U3E/U5E/U6A series controllers.

A.1 PWM Mode Connecting the control cable between the NC unit and the driver

PWM Mode Control Cable Control line connecting NC device and driver								
10336-52A0-008		10350-52A0-008		10336-52A0-008		10350-52A0-008		TWISTED PAIR
PIN	SIGN	PIN	SSIG	PIN	SIGN	PIN	SIGN	
3	ADC_CLK+	1	ADC_CLK+	9	PWM_ATOP+	7	PWM_ATOP+	Twisted Pair
21	ADC_CLK-	2	ADC_CLK-	27	PWM_ATOP-	8	PWM_ATOP-	
4	ADC_STB+	3	ADC_STB+	12	PWM_BBOT+	34	PWM_BBOT+	Twisted Pair
22	ADC_STB-	4	ADC_STB-	30	PWM_BBOT-	35	PWM_BBOT-	
5	ADC_CUA+	26	ADC_CUA+	11	PWM_BTOP+	9	PWM_BTOP+	Twisted Pair
23	ADC_CUA-	27	ADC_CUA-	29	PWM_BTOP-	10	PWM_BTOP-	
6	ADC_CUB+	28	ADC_CUB+	14	PWM_CBOT+	36	PWM_CBOT+	Twisted Pair
24	ADC_CUB-	29	ADC_CUB-	32	PWM_CBOT-	37	PWM_CBOT-	
7	MT_ENA+	15	MT_ENA+	13	PWM_CTOP+	11	PWM_CTOP+	Twisted Pair
25	MT_ENA-	16	MT_ENA-	31	PWM_CTOP-	12	PWM_CTOP-	
8	MT-ALM+	40	MT-ALM+	10	PWM_ABOT+	32	PWM_ABOT+	Twisted Pair
26	MT-ALM-	41	MT-ALM-	28	PWM_ABOT-	33	PWM_ABOT-	
15	GND	5	GND	17	PFM_ENA			
33	GND	13	GND	18	PFM_FLT			
16	5V			35	EGND			
34	5V			36	24V			

Label name		
Cable	Left	Right
1	NC-PWM-CN1	NC-PWM-CN1
2	NC-PWM-CN2	NC-PWM-CN2
3	NC-PWM-CN3	NC-PWM-CN3

NO	Part name	Model	Manufacturer	Quantity
1	Plug	10336-52AD-008	3M	3
2	Plug	10350-52AD-008	3M	3
3	Cable	26-core double-layer shielding (internal cable twisted pair №: 24AWG)		3
4	Cable	AWC16 yellow green		6
5	Heat shrink tube		KSS	6
6	Terminal	RVS 2-4	KSS	3
7	Label tape	MCV-110	KSS	9

Operating point	
●	The cable is shielded twisted pair
●	Shield wires are connected to the enclosures at both ends
●	Heat shrinkable pipe on all welded wire sleeves
Check	
●	Conduction checking
●	Insulation checking
●	Line length (allowable error: 0 ~ 20mm)
●	Check label name

Circuit chart	Model	Number	Date
Lynuc	U3E/U5E/U6A	1/1	10/21/2016
Part number		Picture №	LN002A
Cable name	Permit	Comfirm	Make
LN-IFPMM36-50			FuLN

A.2 PFM Mode Connecting the Control Cable of Yaskawa Drive

PFM Mode Control Cable Control cable connecting Yaskawa drive								
10336-52A0-008		10350-52A0-008		10336-52A0-008		10350-52A0-008		TWISTED PAIR
PIN	SIGN	PIN	SSIG	PIN	SIGN	PIN	SIGN	
5	ENC2_A+	33	ENC_A+	11	PFM_PLUS+	7	SIGN+	Twisted Pair
23	ENC2_A-	34	ENC_A-	29	PFM_PLUS-	8	SIGN-	
6	ENC2_B+	35	ENC_B+	12	PFM_DIR+	11	PULSE+	Twisted Pair
24	ENC2_B-	36	ENC_B-	30	PFM_DIR-	12	PULSE-	
8	ENC2_C+	19	ENC_C+					Twisted Pair
26	ENC2_C-	20	ENC_C-					
15	GND	1	GND	17	ENA	40	PFM_ENA	
33	GND	1	GND	18	FLT	31	PFM_FLT	
16	5V			35	EGND	32	EGND	
34	5V			36	24V	47	24V	

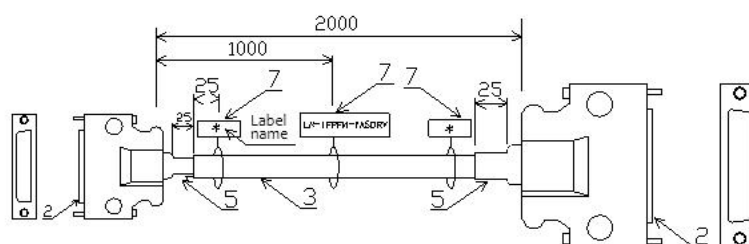

Label name		
Cable	Left	Right
1	NC-PFM-SCS1	NC-PFM-YAS

NO	Part name	Model	Manufacturer	Quantity
1	Plug	10336-52A0-008	3M	1
2	Plug	10350-52A0-008	3M	1
3	Cable	36-core double-layer shielding (internal cable twisted pair №: 24AWG)		1
4	Cable	AWG16 yellow green		2
5	Heat shrink tube		KSS	2
6	Terminal	RYS 2-4	KSS	1
7	Label tape	MCY-110	KSS	3

Operating point
<ul style="list-style-type: none"> The cable is shielded twisted pair Shield wires are connected to the enclosures at both ends Heat shrinkable pipe on all welded wire sleeves
Check
<ul style="list-style-type: none"> Conduction checking Insulation checking Line length (allowable error: 0 ~ 20mm) Check label name

Circuit chart	Model	Number	Date
Lynuc	U3E/U5E/U6A	1/1	10/21/2016
Part number		Picture №	LN002A
Cable name	Permit	Comfirm	Make
LN-IFPFM36-50Y			FuLN

A.3 PFM Mode Connecting Control Cables for Panasonic Drives

PFM Mode Control Cable Control cable connecting Panasonic drive								
10336-52A0-008		10350-52A0-008		10336-52A0-008		10350-52A0-008		TWISTED PAIR
PIN	SIGN	PIN	SSIG	PIN	SIGN	PIN	SIGN	
5	ENC2_A+	21	ENC_A+	11	PFM_PLUS+	44	SIGN+	Twisted Pair
23	ENC2_A-	22	ENC_A-	29	PFM_PLUS-	45	SIGN-	
6	ENC2_B+	48	ENC_B+	12	PFM_DIR+	46	PULSE+	Twisted Pair
24	ENC2_B-	49	ENC_B-	30	PFM_DIR-	47	PULSE-	
8	ENC2_C+	23	ENC_C+					Twisted Pair
26	ENC2_C-	24	ENC_C-					
15	GND	13	GND	17	ENA	29	PFM_ENA	
33	GND	25	GND	18	FLT	37	PFM_FLT	
16	5V			35	EGND	36	EGND	
34	5V			36	24V	7	24V	

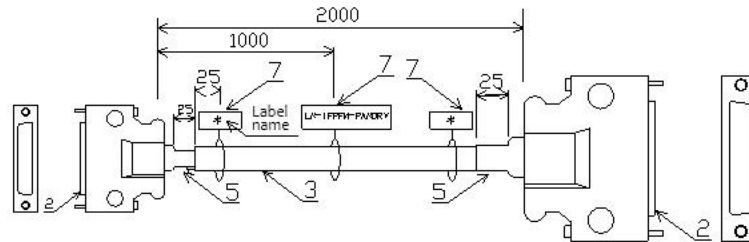

Label name		
Cable	Left	Right
1	NC-PFM-SCS1	NC-PFM-PAN

NO	Part name	Model	Manufacturer	Quantity
1	Plug	10336-52A0-008	3M	1
2	Plug	10350-52A0-008	3M	1
3	Cable	36-core double-layer shielding (internal cable twisted pair №: 24AWG)		1
4	Cable	AWG16 yellow green		2
5	Heat shrink tube		KSS	2
6	Terminal	RYS 2-4	KSS	1
7	Label tape	MCY-110	KSS	3

Operating point
<ul style="list-style-type: none"> ● The cable is shielded twisted pair ● Shield wires are connected to the enclosures at both ends ● Heat shrinkable pipe on all welded wire sleeves
Check
<ul style="list-style-type: none"> ● Conduction checking ● Insulation checking ● Line length (allowable error: 0 ~ 20mm) ● Check label name

Circuit chart	Model	Number	Date
Lynuc	U3E/U5E/U6A	1/1	10/21/2016
Part number		Picture №	LN002A
Cable name	Permit	Confirm	Make
LN-IFPFM36-50P			FuLN

A.4 Control cable for feedback terminal

Feedback terminal definition Connect CN11/12/13/14/15/16 with various feedback cables									
10320-52A0-008		Absolute feedback						NOTE	TWISTED PAIR
PIN	Incremental feedback	SAL	Endat22	BISS-C	NIKON	PANASONIC	TAMAGAWA		
1	0V	0V						Twisted Pair	
2	0V	0V							
3	5V	5V						Twisted Pair	
4	5V	5V							
5		BAT+						Ba Twisted Pair	ited Pair
6		BAT-							
7	A+	DAT+	DAT+	MA+(CLK+)	SD+	PS+	DAT+	Twisted Pair	
8	A-	DAT-	DAT-	MA-(CLK-)	SD-	PS-	DAT-		
9	B+		CLK+	SLO+(DAT+)				Twisted Pair	
10	B-		CLK-	SLO-(DAT-)					
11	C+							Twisted Pair	
12	C-								
13-20									

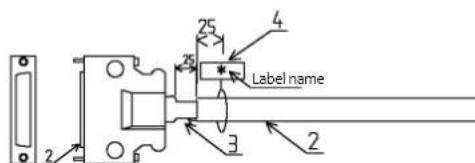

Label name		
Cable	Left	Right
1	NC-ENC-CN11	ENC (X)
2	NC-ENC-CN12	ENC (Y)
3	NC-ENC-CN13	ENC (Z)

NO	Part name	Model	Manufacturer	Quantity
1	Plug	10320-52A0-008	3M	3
2	Cable	50-core double-layer shielding (internal cable twisted pair №: 24AWG)		3
3	Cable	AWG16 yellow green		6
4	Heat shrink tube		KSS	6
5	Terminal	RVS 2-4	KSS	3
6	Label tape	MCV-110	KSS	9

Operating point
<ul style="list-style-type: none"> The cable is shielded twisted pair Shield wires are connected to the enclosures at both ends Heat shrinkable pipe on all welded wire sleeves
Check
<ul style="list-style-type: none"> Conduction checking Insulation checking Line length (allowable error: 0 ~ 20mm) Check label name

Circuit chart	Model	Number	Date
Lynuc	U3E/U5E/U6A	1/1	10/21/2016
Part number		Picture №	LN002A
Cable name	Permit	Comfirm	Make
ENC-CN11-20-2.0			FuLN

A.5 CN9 Control Cable for Connecting Yaskawa Drive

CN9 cable Control cable connecting Yaskawa drive									
10326-52A0-008		10350-52A0-008		10326-52A0-008		10350-52A0-008		TWISTED PAIR	
PIN	SIGN	PIN	SSIG	PIN	SIGN	PIN	SIGN		
1	A	33	A	3	C	19	C	Twisted Pair	
10	A/	34	A/	12	C/	20	C/		
2	B	35	B	5	P	7	P	Twisted Pair	
11	B/	36	B/	14	P/	8	P/		
6	S	11	S					Twisted Pair	
15	S/	12	S/						
13	0V	1	0V	23	IN2	-	-		
4	5V	-	-	24	IN3	-	-		
19	OUT1/ENA	40	OUT1/ENA	7	IN4	-	-		
20	OUT2	-	-	17	IN5	-	-		
21	OUT3	-	-	8	IN6	-	-		
16	OUT4	-	-	18	INCOM	-	-		
22	INI/FTL	31	INI/FTL	25	OUTCOM	-	-		
9,25	EGND	32	EGND	26,18	24V	47	24V		

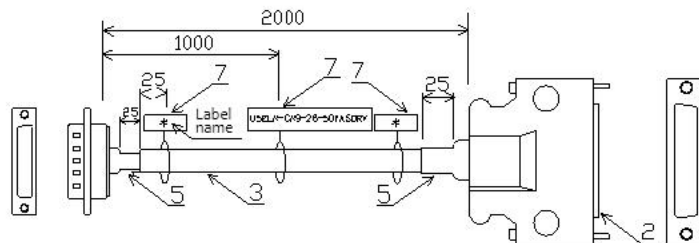

Label name's		
Cable	Left	Right
1	U5E/U6A-CN9	NC-YASKAWA
2	U5E/U6A-CN9	NC-YASKAWA
3	U5E/U6A-CN9	NC-YASKAWA

N0	Part name	Model	Manufacturer	Quantity
1	Plug	10326-52A0-008	3M	1
2	plug	10350-52A0-008	3M	1
3	Cable	36-core double-layer shielding (internal cable twisted pair №: 24AWG)		1
4	Cable	AWG16 yellow green		2
5	Heat shrink tube		KSS	2
6	Terminal	RVS 2-4	KSS	1
7	Label tape	MCV-110	KSS	3

Operating point	
●	The cable is shielded twisted pair
●	Shield wires are connected to the enclosures at both ends
●	Heat shrinkable pipe on all welded wire sleeves
Check	
●	Conduction checking
●	Insulation checking
●	Line length (allowable error: 0 ~ 20mm)
●	Check label name

Circuit chart	Model	Number	Date
Lynuc	U3E/U5E/U6A	1/1	1/17/2016
Part number		Picture №	LN002A
Cable name	Permit	Confirm	Make
LN-CN9-26-50Y-2.0			FuLN

A.6 CN9 Control cable for connecting Panasonic drives

CN9 cable Control cable connecting Panasonic drive								
10326-52A0-008		10350-52A0-008		10326-52A0-008		10350-52A0-008		TWISTED PAIR
PIN	SIGN	PIN	SSIG	PIN	SIGN	PIN	SIGN	
1	A	21	A	3	C	23	C	Twisted Pair
10	A/	22	A/	12	C/	24	C/	
2	B	48	B	5	P	44	P	Twisted Pair
11	B/	49	B/	14	P/	45	P/	
6	S	46	S					Twisted Pair
15	S/	47	S/					
13	0V	13,25	0V	23	IN2	-	-	
4	5V	-	-	24	IN3	-	-	
19	OUT1/ENA	29	OUT1/ENA	7	IN4	-	-	
20	OUT2	-	-	17	IN5	-	-	
21	OUT3	-	-	8	IN6	-	-	
16	OUT4	-	-	18	INCOM	-	-	
22	IN1/FTL	37	IN1/FTL	25	OUTCOM	-	-	
9,25	EGND	36	EGND	26,18	24V	7	24V	

Label name		
Cable	Left	Right
1	USBNC-CN9	NC-Panasonic
2	USBNC-CN9	NC-Panasonic
3	USBNC-CN9	NC-Panasonic

NO	Part name	Model	Manufacturer	Quantity
1	Plug	10326-52A0-008	NSXD	3
2	Plug	10350-52A0-008	3M	3
3	Cable	26-core double-layer shielding (internal cable twisted pair №: 24AWC)		3
4	Cable	AWC16 yellow green		6
5	Heat shrink tube		KSS	6
6	Terminal	RVS 2-4	KSS	3
7	Label tape	MCV-110	KSS	9

Operating point			
●	The cable is shielded twisted pair		
●	Shield wires are connected to the enclosures at both ends		
●	Heat shrinkable pipe on all welded wire sleeves		
Check			
●	Conduction checking		
●	Insulation checking		
●	Line length (allowable error: 0 - 20mm)		
●	Check label name		

Circuit chart	Model	Number	Date
Lynuc	U3E/U5E/U6A	1/1	1/17/2016
Part number	Picture №		
	LN002A		
Cable name		Permit	Comfirm
LN-CN9-26-50P-2, 0			FuLN

A.7 CN9 Connecting Control Cables for Magmetric Drives

CN9 cable Control cable connecting Megmeet driver								
10326-52A0-008		10350-52A0-008		10326-52A0-008		10350-52A0-008		TWISTED PAIR
PIN	SIGN	PIN	SSIG	PIN	SIGN	PIN	SIGN	
1	A	17	A	3	C	19	C	Twisted Pair
10	A/	42	A/	12	C/	44	C/	
2	B	18	B	5	P	20	P	Twisted Pair
11	B/	43	B/	14	P/	21	P/	
6	S	45	S					Twisted Pair
15	S/	46	S/					
13	0V	30	0V	23	IN2	-	-	
4	5V	-	-	24	IN3	-	-	
19	OUT1/ENA	9	OUT1/ENA	7	IN4	-	-	
20	OUT2	-	-	17	IN5	-	-	
21	OUT3	-	-	8	IN6	-	-	
16	OUT4	-	-	18	INCOM	-	-	
22	INI/FTL	38	INI/FTL	25	OUTCOM	-	-	
9,25	EGND	39	EGND	26,18	24V	48	24V	

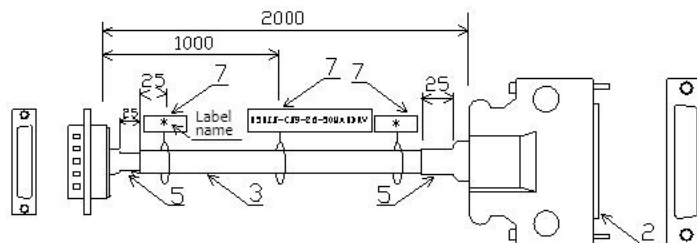

Label name		
Cable	Left	Right
1	U5ENC-CN9	NC-Maegmeet
2	U5ENC-CN9	NC-Maegmeet
3	U5ENC-CN9	NC-Maegmeet

NO	Part name	Model	Manufacturer	Quantity
1	Plug	10326-52A0-008	N5XD	3
2	Plug	10350-52A0-008	3M	3
3	Cable	36-core double-layer shielding (internal cable twisted pair №: 24AWG)		3
4	Cable	AWG16 yellow green		6
5	Heat shrink tube		KSS	6
6	Terminal	RVS 2-4	KSS	3
7	Label tape	MCV-110	KSS	9

Operating point	
●	The cable is shielded twisted pair
●	Shield wires are connected to the enclosures at both ends
●	Heat shrinkable pipe on all welded wire sleeves
Check	
●	Conduction checking
●	Insulation checking
●	Line length (allowable error: 0 ~ 20mm)
●	Check label name

Circuit chart	Model	Number	Date
Lynuc	U3E/U5E/U6A	1/1	1/17/2016
Part number		Picture №	LNO02A
Cable name		Permit	Comfirm
LN-CN9-26-50M-2.0			Make
			FuLN

LYNUC

Shanghai Lynuc Numerical Control Technology Co.

Address: No.30-31, Lane 2338, Metropolitan Road, Minhang District, Shanghai,
China

Zip code: 201108

Tel: +86 21 61837766

Fax: +86 21 60720487

Website: <http://www.lynuc.cn>